

Durostone®

连接件

Fasteners



# 合成樹脂に込められた専門技能

## Competence in Plastics

ドイツのマンハイム市に本社を置くロシュリンググループは、世界各国に多数の支社を展開しています。数千人にも及ぶ従業員とともに、ロシュリングは世界中の顧客や各国のマーケットが動いている現地で製品を製造しています。ロシュリングの3事業部、インダストリアル、オートモーティブ、メディカル事業部は、欧州、北中南米、そしてアジアの各大陸に展開し、合計で毎年数十億ユーロ（数千億円）の売上を上げています。

### Röchling Industrial

インダストリアル事業部 Industrial では、ほぼ全ての産業分野において、アプリケーションを重視した最適な素材をご提供します。ロシュリングは、世界で最も種類が豊富な熱可塑性樹脂とコンポジットの製品群をご用意しています。シートや丸棒、パイプやプレート、中型品などの半製品、同様にプロファイルや加工 組立精密部品を製造しています

The Röchling Group, which is headquartered in Mannheim, includes a large number of locations in countries all over the world. With a workforce of several thousand employees, we manufacture our products in close proximity to our customers and markets. Our three company divisions, Industrial, Automotive and Medical, generate billions in sales every year on the European, American and Asian continents.

### Röchling Industrial

The Industrial division supplies almost every sector of industry with optimal, application-oriented materials. To achieve this, Röchling has probably the world's biggest product portfolio of thermoplastics and composite materials. The company manufactures a range of semi-finished parts such as sheets, rods, tubes, flat bars, finished castings and profiles as well as machined and assembled precision components.

## 内容目録

Durostone® 接続件	3
应用领域	4
转矩/扭力/预应力	6
板料技术参数	7
Durostone® EPR S1	8
Durostone® EPR S5	10
Durostone® EPR S6	12
Durostone® UPR S19	14
Durostone® EPM S7 螺母	16
Durostone® EPM S7 方形垫片	18
Durostone® EPC 308 (M8 – M20)	18
Durostone® EPM S7 (M24 – M30) 圆形垫片	18

## Content

Durostone® Fasteners	3
Applications	4
Torque/Torsion/Pre-load	6
Technical data: sheet material	7
Durostone® EPR S1	8
Durostone® EPR S5	10
Durostone® EPR S6	12
Durostone® UPR S19	14
Durostone® EPM S7 Nuts	16
Durostone® EPM S7 Square washer	18
Durostone® EPC 308 (M8 – M20)	18
Durostone® EPM S7 (M24 – M30) Round washer	18

## Durostone® 连接件 有什么出众的性能?

Durostone® 连接件应用于对电气特性、化学特性和热特性提出很高要求的技术领域。Durostone® 连接件以带有特别的添加剂和特殊结构的玻璃纤维增强环氧树脂系统或聚酯树脂系统为基础。



### 电气特性

所有的 Durostone® 连接件是不导电的和非磁的。另外还有几个特性，在高的电场强度无局部放电，特别无漏电起痕。因此，它们极其适合应用于变压器、电机制造、高频设备、配电设备以及静电粉末涂装设备。



### 化学特性

Durostone® 连接件具有特别的抵抗腐蚀性介质和气体、变压器油和电介质液体的特性，有很强的抗紫外线辐射能力和耐候性。例如，连接件可以应用于化工设备制造方面如废气脱硫设备以及电缆线盒，可应用于陆上及海上技术方面如海水脱盐以及污水净化处理和电缆线盒。



### 热学特性

与钢(15 – 58 W/mk)相比，所有的 Durostone® 连接件具有很低的导热性，为 0.3 W/mK，相当于在建筑中用作隔热材料的矿棉的导热性。因此，Durostone® 连接件非常适合应用于制冷和暖通空调工程，以及必须避免热桥的领域。



### 重量轻

Durostone® 连接件的密度为 1.9 至 2g/cm<sup>3</sup>，重量大约只有钢的1/4。因此，Durostone® 连接件非常适合以降低重量为重要因素的领域中 -- 例如应用于汽车制造或者是风力发电轮机的吊舱的建造。



### 高抗拉强度

与由热塑性塑料制造，比如由聚酰胺制造的螺杆相比，Durostone® 螺杆有六倍的抗拉强度。

## What distinguishes Durostone® fasteners?

Durostone® fasteners are used in technical fields that have high demands on electrical, chemical and thermal properties. Durostone® fasteners are based on glass fibre-reinforced epoxy or polyester resin systems with special additives and a special structure.



### Electrical properties

All Durostone® fasteners are **electrically insulating** and **non-magnetic**. Some qualities are, moreover, **partial discharge free** up to high electric field strengths and especially **non-tracking**. They are excellent for use in transformers, in electrical engineering, in high-frequency, switching and electrostatic powder coating equipment.



### Chemical properties

Durostone® fasteners are particularly **resistant** against **aggressive fluids and gases, resistant to transformer oil and dielectric liquids, and highly UV and weather resistant**. They are in use, for example, in chemical equipment, flue gas desulfurization and cable trays, the onshore and offshore technology, seawater desalination, wastewater treatment and cable trays.



### Thermal properties

Compared to steel (15 – 58 W/mk), all Durostone® qualities have a very **low thermal conductivity** of 0.3 W/mK, and are therefore at the level of mineral wool, which is used in construction as insulation. They are ideal for use in refrigeration, HVAC and areas suitable for applications, where thermal bridges must be avoided.



### Lightweight

Durostone® fasteners have a density of 1.9 to 2 g/cm<sup>3</sup> and thus weigh only about 1/4 of steel. They are well-suited for applications where weight reduction is an important factor – for example, in vehicle construction or the construction of nacelles for wind turbines.



### High tensile strength

Compared to threaded rods made of thermoplastic such as for example polyamide, Durostone® threaded rods have a six-fold higher tensile strength.

## 应用领域

- 废气脱硫设备
- 陆上/海上工程
- 化工厂
- 水利工程、污水净化处理设备、海水脱盐
- 变压器(干式和油浸式)
- 发电机
- 开关设备制造
- 测量仪器制造、高频设备
- 交通工程
- 制冷和空调技术
- 电缆线盒
- 静电粉末涂装
- 电镀设备

为了达到您的应用目的, 请您联系我们以选择具有合适特性的 Durostone® 连接件。我们根据您的负荷需求, 为您提供理想的品质。

### 电镀设备

Electroplating plants



## Applications

- Flue gas desulphurization plants
- Onshore/offshore engineering
- Chemical plants
- Hydraulic engineering, sewage treatment plants, desalination of seawater
- Transformers, dry-type and oil immersed
- Generators
- Switchgears
- Instrument construction, high-frequency systems
- Traffic engineering
- Refrigeration and air conditioning
- Cable trays
- Electrostatic powder coating
- Electroplating plants

Please contact us for choosing the right Durostone® grade for your application. We examine the loads and offer a grade suitable for your particular application.

### 发电机

Generators

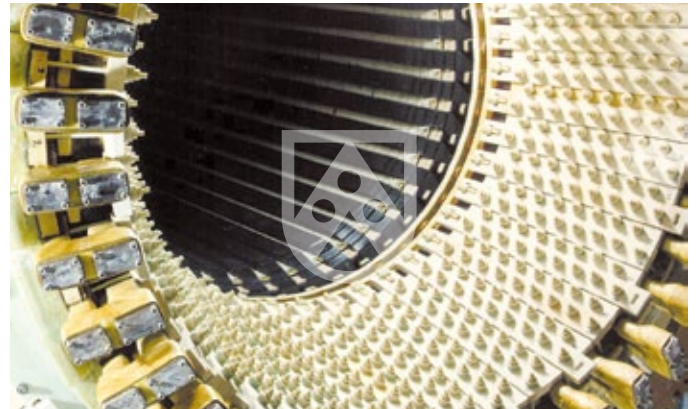

### 变压器

Transformer

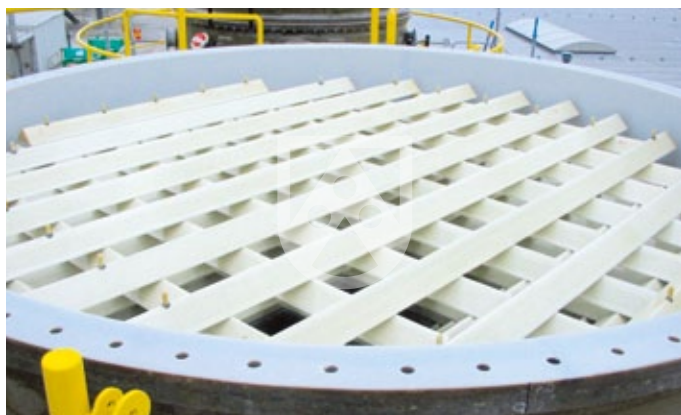

废气脱硫设备  
Flue gas desulphurization plant



化工厂  
Chemical plants

陆上/海上工程  
Onshore/offshore engineering



## 转矩/扭力/预应力

与钢相比, Durostone® 玻璃纤维强化螺杆和螺母具有相对较高的螺纹摩擦系数。这导致在低的预应力时就出现了对于螺杆较高的扭力负荷, 这种扭力负荷可能导致螺杆提前失效, 而没有达到可承受的最大预应力。

为了能够充分利用 Durostone® 螺杆的设计强度, 我们建议采取以下的措施:

- 降低螺纹摩擦力, 通过:
  - 给螺纹上油
  - 给螺杆/螺母加聚四氟乙烯涂层
  - 给螺纹涂上合适的胶粘剂 (同时也能锁紧螺母)
- 给部件预加应力 – 通过这样能够无应力拧紧螺纹连接。
- 使用扭矩扳手以稳定地夹紧

## Torque/Torsion/Pre-load

Durostone® glass fibre reinforced threaded rods and nuts are having a relatively high coefficient of thread friction compared to steel. This is causing high torsional loads for the threaded rod already at low pre-loads. These high torsional loads can lead to premature failure, without reaching the tolerable maximum pre-load.

To ensure the high strength of Durostone® threaded rods we recommend the following measures:

- Reduce the thread friction by:
  - Oiling the threads
  - Teflon coating for the threaded rods/nuts
  - Coating the threads with a suitable adhesive (Simultaneous screw locking)
- Pretension of components, which allows a tension-free tightening of the screw
- The use of torque wrenches for a uniform clamping



# 技术参数

## Technical Data

### Durostone® 板料

#### Durostone® sheet material

		测试方法 Test method	单位 Unit	EPR S1	EPR S5	EPM S7	EPR S6	UPR S19
标准颜色 Standard colour		-	-	红色 red	自然色 natural	自然色 natural	自然色 natural	自然色 natural
树脂种类 Type of resin		-	-	环氧树脂 epoxy	环氧树脂 epoxy	环氧树脂 epoxy	环氧树脂 epoxy	聚酯 polyester
密度 Specific gravity	ca. approx.	ISO 1183 meth 1	g/cm <sup>3</sup>	1.90	1.90	1.90	2.00	1.95
防火性能 Flammability		UL 94	-	-	-	-	VO	-

#### 主纤维增强方向的机械特性

##### Mechanical properties in main reinforcement sense

在垂直方向的抗弯强度 Bending strength	⊥	ISO 178	MPa	500	500	300	650	350
垂直方向的弹性模量 Modulus of elasticity	⊥	ISO 178	GPa	20	20	15	30	20
垂直方向的抗压强度 Compressive strength	⊥	ISO 604	MPa	300	300	550	400	450
抗冲击强度 (简支梁冲击试验) Impact strength (Charpy)		ISO 179	kJ/m <sup>2</sup>	100	100	200	300	200
抗拉强度 Tensile strength		ISO 527	MPa	400	400	250	500	400
破坏强度 Delamination load		DIN 53463	N	4000	4000	4000	4000	4000

#### 电气特性

##### Electrical properties

体积电阻 Volume resistivity		IEC 60093	Ω X cm	10 <sup>14</sup>	10 <sup>14</sup>	10 <sup>14</sup>	10 <sup>14</sup>	10 <sup>14</sup>
表面电阻 Surface resistivity		IEC 60093	Ω	10 <sup>13</sup>	10 <sup>13</sup>	10 <sup>13</sup>	10 <sup>14</sup>	10 <sup>10</sup>
在 90 °C 时的电气强度 Electric strength at 90 °C	⊥	IEC 60243-1	kV/mm	13	13	10	15	15
在 48-62Hz 情况下的相对电容率 (介电常数) Relative permittivity at 48-62 Hz	ca. approx.	IEC 60250	ε <sub>r</sub>	5	5	5	5	5
相比漏电起痕指数 Comparative tracking index		IEC 60112	CTI	225	225	225	600	600

#### 热特性

##### Thermal properties

线性膨胀系数 Coefficient of linear expansion		-	10 <sup>-6</sup> K <sup>-1</sup>	10-20	10-20	10-20	10-20	10-20
导热性 Thermal conductivity		ISO 8302	W/m K	0.3	0.3	0.3	0.3	0.3
耐温 <sup>1)</sup> Thermal Endurance <sup>1)</sup>		IEC 60216	T.I.	180	180	180	180	155
绝缘等级 Insulating class		IEC 60085	-	H	H	H	H	F

<sup>1)</sup> 耐热温度和绝缘等级是根据 IEC 60216 基于在 20000 h 之后抗弯强度的改变 (50%) 来确定的。

⊥ = 与层垂直 || = 与层平行

在这个手册中的上述参数值是平均值, 通过现有的统计试验与检测确定。  
上述数据仅是提供信息, 除非在销售合同中另有明确协议, 否则不具有约束力。

<sup>1)</sup> The temperature limit and insulating class have been specified in accordance with IEC 60216 on the basis of the change in bending strength (50%) after 20000 h.

⊥ = perpendicular to the lamination || = parallel to the lamination

The data mentioned in this brochure are average values ascertained by current statistical returns and tests. The above data is provided purely for information and shall not be regarded as binding unless expressly agreed in a contract of sale.

# Durostone® EPR S1

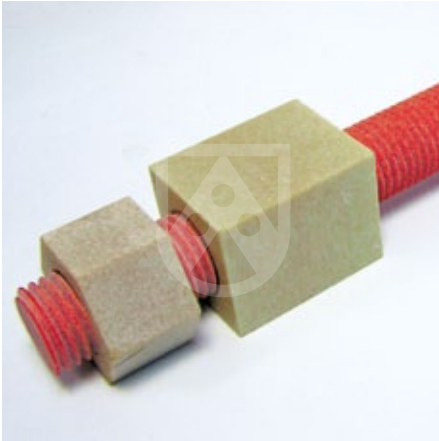
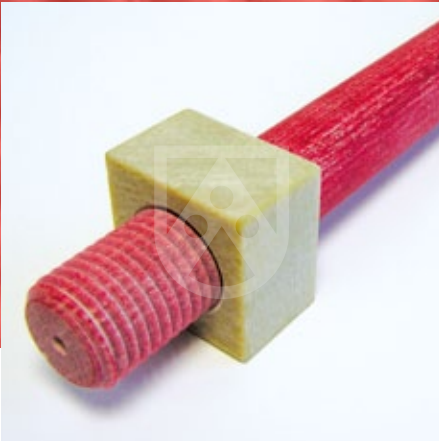



# Durostone® EPR S1

Durostone® EPR S1 螺杆由一个专门设计的强化玻璃纤维和融入的环氧树脂矩阵组成。

Durostone® EPR S1 是我们的标准等级螺杆，几十年来成功应用于许多不同的领域。

- 标准长度: 1900 mm
- 标准直径: M8 – M30
- 螺纹公差按照 ISO 965
- 公差等级为 6 g, 所有尺寸为毫米。

根据需求可制造更大尺寸的产品

用于机车牵引变压器的带有 Durostone® 连接件的 Lignostone® 构件  
Lignostone® component with Durostone® fastener for a traction transformer

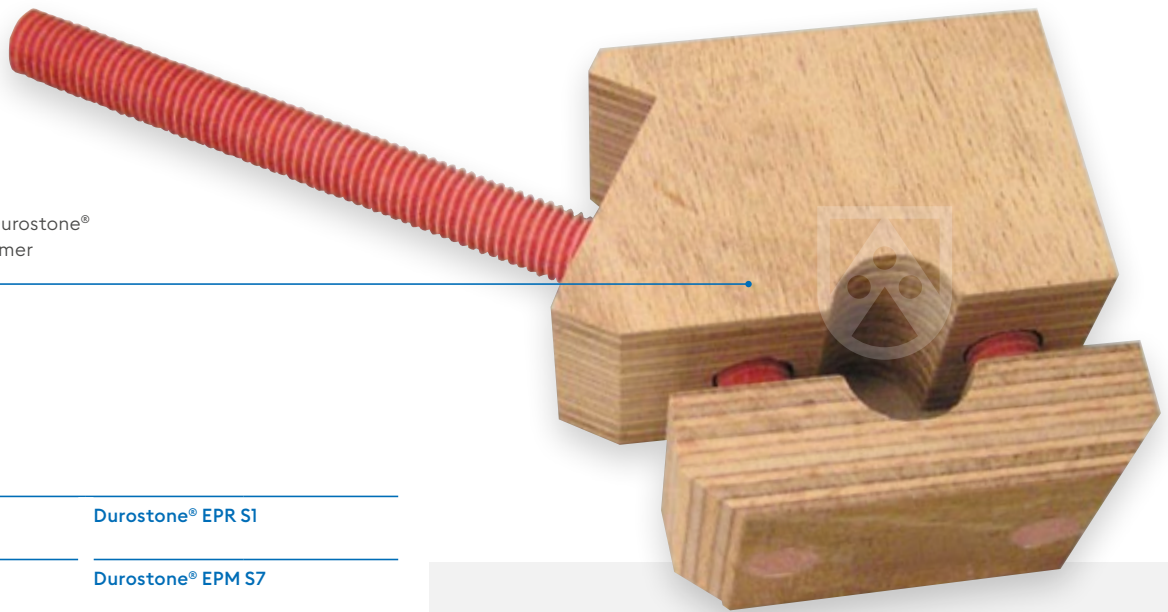

## 极限荷载 <sup>1)</sup>

### Breaking load <sup>1)</sup>

螺杆 Threaded rod	Durostone® EPR S1	
螺母 Nut	Durostone® EPM S7	
额定直径 Nominal diameter	螺母高度 Nut height H = D	螺母高度 Nut height H = 2 D
M6	4000 N	6500 N
M8	7000 N	12000 N
M10	12000 N	22000 N
M12	17500 N	31000 N
M16	32000 N	58000 N
M20	50000 N	80000 N
M24	67000 N	110000 N
M27	90000 N	145000 N
M30	110000 N	170000 N

<sup>1)</sup> 平均值。设计中应考虑相应的安全系数。

常用负载应该小于短时极限负载的 50 %。

Average values. Corresponding safety factors should be considered in the design. A constant tensile load should be less than 50 % of the achieved short time breaking load.

# Durostone® EPR S1

Durostone® EPR S1 threaded rods consist of two main components, a special designed glass reinforcement and an embedding epoxy resin matrix.

Durostone® EPR S1 is our standard grade for threaded rods and is successfully used for decades in many different areas.

- Standard length: 1900 mm
- Standard size: M8 – M30
- Threads in accordance with ISO 965
- Tolerance zone 6 g, all sizes in mm

Larger sizes on request.

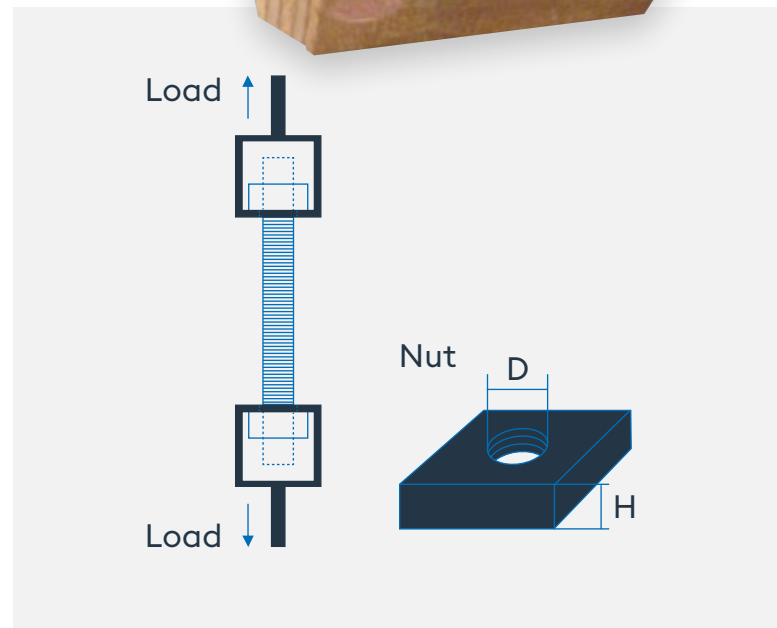

使用的试验参量设置, 拉伸速度: 5 mm/min, 夹具距离: 250 mm

Used test set-up, Pulling speed: 5 mm/min, Clamping length: 250 mm

# Durostone® EPR S5

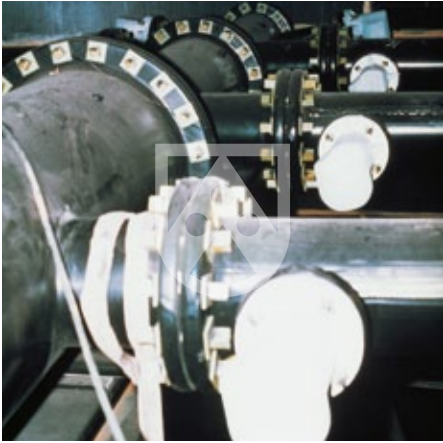
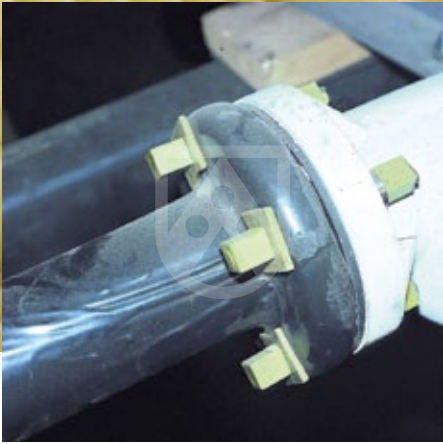
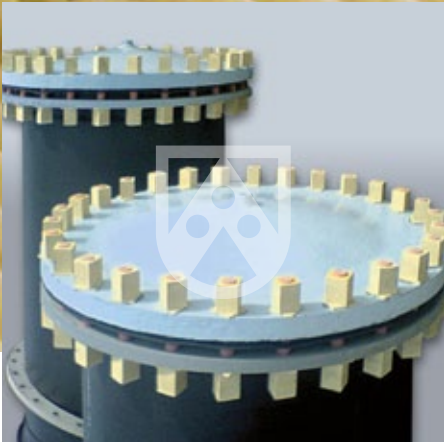

# Durostone® EPR S5

Durostone® EPR S5 螺杆特别耐腐蚀性的介质, 因此在化工和海洋工程优先得到应用。

- 螺纹公差按照 ISO 965
- 公差等级为 6 g, 所有尺寸为毫米
- 标准长度: 1900 mm
- 标准直径: M8 – M30

## 在酸性的介质里允许的承受值<sup>1)</sup>

### Permissible load values in acidic medium<sup>1)</sup>

螺杆 Threaded rod	Durostone® EPR S5			
螺母 Nut	Durostone® EPM S7			
额定直径 Nominal diameter	pH 值 = 3.5–6 pH-value = 3.5–6		pH 值 = 1 pH-value = 1	
	螺母高度 Nut height H = D	螺母高度 Nut height H = 2 D	螺母高度 Nut height H = D	螺母高度 Nut height H = 2 D
M8	1400 N	3100 N	650 N	1500 N
M10	2550 N	5000 N	1100 N	2150 N
M12	3750 N	7450 N	1600 N	3100 N
M16	6800 N	13600 N	2900 N	5600 N
M20	10600 N	20450 N	4500 N	8700 N
M24	15150 N	27250 N	6500 N	11800 N
M27	19400 N	33300 N	8300 N	14800 N
M30	23000 N	43000 N	10100 N	19000 N

<sup>1)</sup> 负荷值适用于温度 70 °C, 负荷时间为 2 x 10<sup>5</sup> 小时且 pH 值=3.5–6 或者 5 年且 pH 值=1 的情况下。pH 值的定义是以含有高比例的氯化物和硫酸盐的试验悬浮液为基础。

<sup>1)</sup> Load values apply for temperatures of 70 °C and a load duration of 2 x 10<sup>5</sup> hours at pH = 3.5–6 respective 5 years pH = 1. The pH-value is based on a defined test suspension with high chloride and sulphate contents.

化工厂

Chemical plants



# Durostone® EPR S5

Durostone® EPR S5 threaded rods are highly resistant to aggressive media and can be used for **chemical and maritime applications**.

- Threads in accordance with ISO 965
- Tolerance zone 6 g, all sizes in mm
- Standard length: 1900 mm
- Standard size: M8 – M30

陆上/海上工程

Onshore/offshore engineering



# Durostone® EPR S6

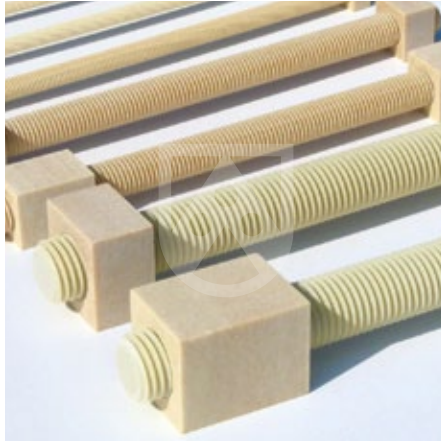
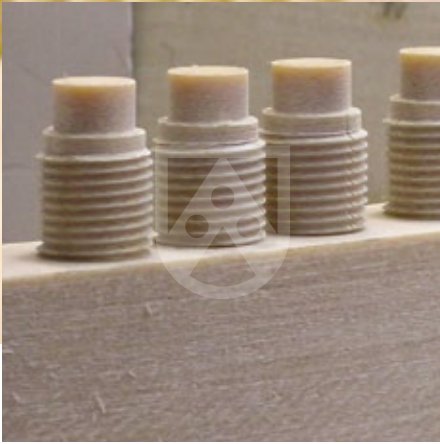

# Durostone® EPR S6

Durostone® EPR S6 是专为螺杆研发的具有耐高压的优良技术特性的环氧层压塑料。

## 特性

- 高抗拉强度和高弹性模量
- 非常高的相比耐漏电起痕指数 CTI 600
- 阻燃特性 V0
- 直径可达 M52\* 及 长度达 5500 mm

\* 根据需求可制造更大尺寸的产品

## 极限荷载<sup>1)</sup>

### Breaking load<sup>1)</sup>

螺杆 Threaded rod	Durostone® EPR S6	
螺母 Nut	Durostone® EPM S7	
额定直径 Nominal diameter	螺母高度 Nut height $H = D$	螺母高度 Nut height $H = 2 D$
M8	7000 N	12000 N
M10	12000 N	22000 N
M12	17500 N	31000 N
M16	32000 N	58000 N
M20	50000 N	85000 N
M24	67000 N	120000 N
M27	90000 N	150000 N
M30	110000 N	180000 N

<sup>1)</sup> 平均值。设计中应考虑相应的安全系数。  
常用负载应该小于短时极限负载的50%。

Average values. Corresponding safety factors should be considered in the design. A constant tensile load should be less than 50 % of the achieved short time breaking load.

# Durostone® EPR S6

Durostone® EPR S6 is a special for threaded rods developed epoxy high pressure laminate with outstanding technical properties.

## Features

- High tensile strength and high tensile modulus
- Very high tracking resistance CTI 600
- Flammability V0
- Sizes up to M52\* and 5500 mm length are possible

\* Larger sizes on request

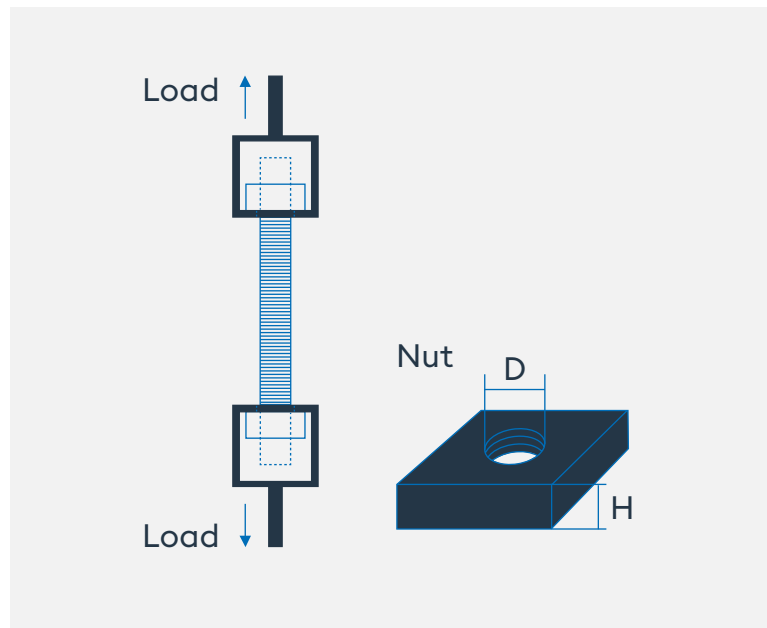

使用的试验参量设置, 拉伸速度: 5 mm/min,  
夹具距离: 250 mm  
Used test set-up, Pulling speed: 5 mm/min,  
Clamping length: 250 mm

# Durostone® UPR S19

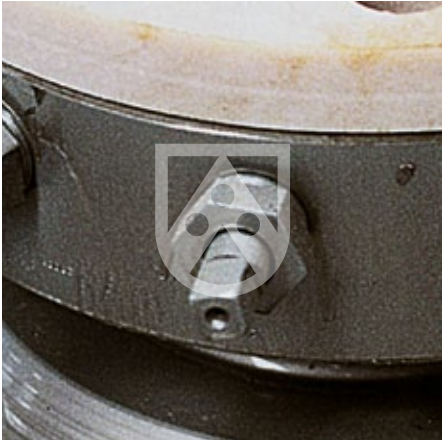

# Durostone® UPR S19

Durostone® UPR S19 是一款按照片状模塑料工艺 (SMC) 由乙烯基酯树脂和玻璃纤维制成的螺杆。

## 特性

- 满足高介电要求的VE-树脂
- 在高的电场强度无局部放电\*
- 非常高的相比耐漏电起痕指数, CTI 600
- 直径可达 M52 及长度达5300 mm

\* 要获得更多信息, 请联系我们

## 极限荷载<sup>1)</sup>

### Breaking load<sup>1)</sup>

螺杆 Threaded rod	Durostone® UPR S19	
螺母 Nut	Durostone® UPR S19	
额定直径 Nominal diameter	螺母高度 Nut height H = D	螺母高度 Nut height H = 2 D
M8	5000 N	8000 N
M10	8000 N	15000 N
M12	12000 N	22000 N
M16	20000 N	40000 N

<sup>1)</sup> 平均值。设计中应考虑相应的安全系数。  
常用负载应该小于短时极限负载的50%。

Average values. Corresponding safety factors should be considered in the design. A constant tensile load should be less than 50 % of the achieved short time breaking load.



# Durostone® UPR S19

Durostone® UPR S19 is a threaded rod made of VE-resin and glass fibres using the Sheet-Molding-Compound-technology (SMC).

## Features

- VE-resin for high dielectric requirements
- Partial discharge free up to high electric field strength\*
- High tracking resistance CTI 600
- Sizes up to M52 and 5300 mm are possible

\* Please contact us for further information

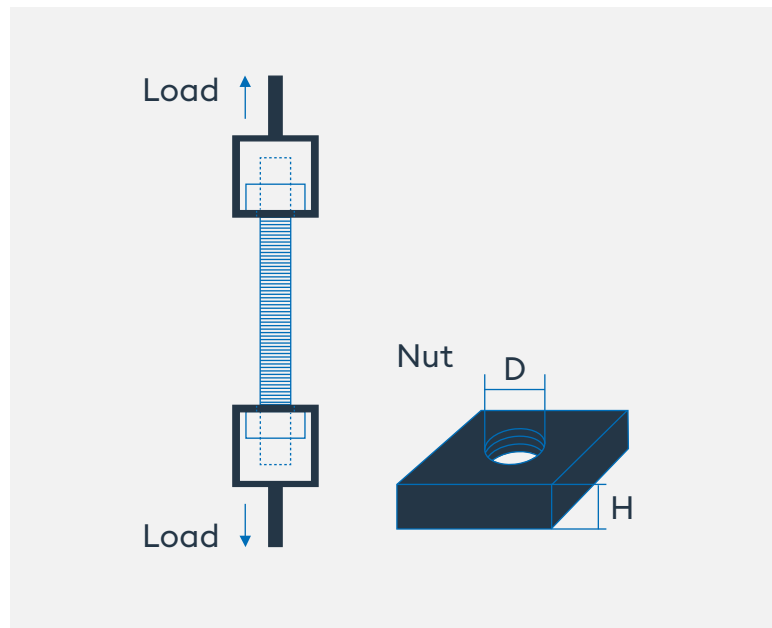

使用的试验参量设置, 拉伸速度: 5 mm/min,  
夹具距离: 250 mm

Used test set-up, Pulling speed: 5 mm/min,  
Clamping length: 250 mm

Durostone<sup>®</sup> EPM S7

螺母 | Nuts





# Durostone® EPM S7

## 螺母

内螺纹的高度对于 Durostone® 连接件的 抗拉强度至关重要。在使用螺母高度为  $H = D$  的螺母的情况下, Durostone® 螺栓的抗拉强度没有被充分利用。我们建议使用螺母高度为  $H = 2D$  或者是更高的 Durostone® 螺母。

- 标准直径: M8 – M30
- 螺母标准高度:  $H = D$  或者  $H = 2 D$

根据需求我们也生产其它等级和尺寸的 Durostone® 螺母。除了以上列举的公制 尺寸的螺母, 我们也制造英制螺纹尺寸的 Durostone® 螺母。

# Durostone® EPM S7

## Nuts

The height of the nut thread is crucial for the tensile strength of Durostone® fasteners. By using nuts with a nut height of  $H = D$ , the tensile strength of Durostone® threaded rods is not fully utilized. We recommend Durostone® nuts with a nut height  $H = 2 D$  or greater.

- Standard size: M8 – M30
- Standard nut height:  $H = D$  or  $H = 2 D$

On request, we also manufacture Durostone® nuts in other grades and sizes. In addition to the listed metric sizes, we manufacture Durostone® nuts also in inch thread sizes.

尺寸 Size	螺母孔径 Core diameter d		SW	H = D/2 D	e 1	e 2
	mm	公差, 单位: mm tol. in mm	tol. 0/-0.5	tol. +1/-0.3	mm	mm
M8	6.6	+0.3/0	13	8/16	18.4	15.0
M10	8.4	+0.3/0	17	10/20	24.0	19.6
M12	10.1	+0.3/0	19	12/24	26.9	21.9
M16	13.8	+0.4/0	24	16/32	33.9	27.7
M20	17.3	+0.5/0	30	20/40	42.4	34.6
M24	20.8	+0.5/0	36	24/48	50.9	41.6
M27	23.8	+0.5/0	41	27/54	58.0	47.4
M30	26.2	+0.5/0	46	30/60	65.0	53.1

Durostone® 方螺母  
Durostone® square nut

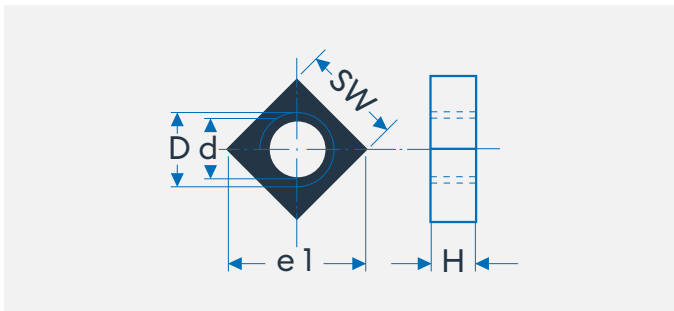

Durostone® 六角螺母  
Durostone® hexagonal nut

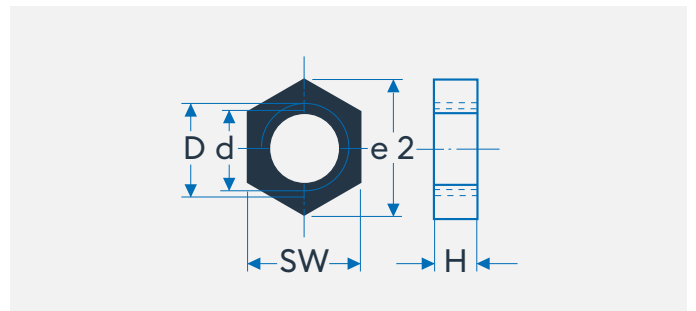

螺纹公差按照ISO965, 公差等级为6H, 所有尺寸为毫米。  
Threads in accordance with ISO 965, tolerance zone 6H, all sizes in mm.

## Durostone® EPM S7

### 方形垫片

### Square washer

尺寸 Size	棱边长度 Edge length	孔直径 Bore diameter	厚度 Thickness
	A	B	C
	mm	mm	mm
M6	25	7	4
M8	30	9	4
M10	30	11	4
M12	30	13	4
M16	40	17	5
M16	50	17	5
M20	50	21	5
M24	50	25	5
M27	50	28	5
M30	50	31	5

根据需求制造其它尺寸和等级的产品。  
Other sizes and qualities on request.

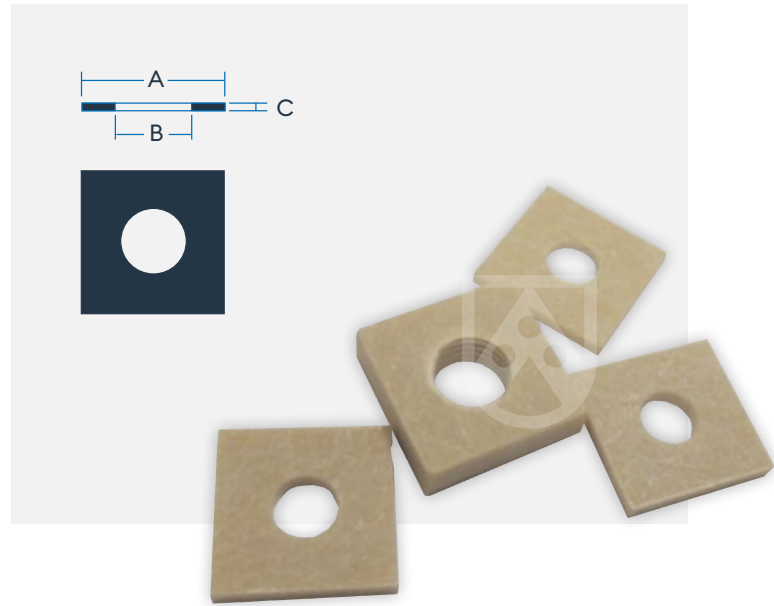

## Durostone® EPC 308 (M8 – M20)

## Durostone® EPM S7 (M24 – M30)

### 圆形垫片

### Round washer

尺寸 Size	棱边长度 Edge length	孔直径 Bore diameter	厚度 Thickness
	A	B	C
	mm	mm	mm
M8	18	9	1.5 ± 0.3
M10	22	11	2 ± 0.3
M12	27	14	2.5 ± 0.4
M14	30	16	2.5 ± 0.4
M16	32	18	3 ± 0.5
M18	36	20	3 ± 0.5
M20	40	22	3 ± 0.5
M24	50	27	4 ± 0.6
M27	55	30	4 ± 0.6
M30	60	33	4 ± 0.6

根据需求制造其它尺寸和等级的产品。  
Other sizes and qualities on request.

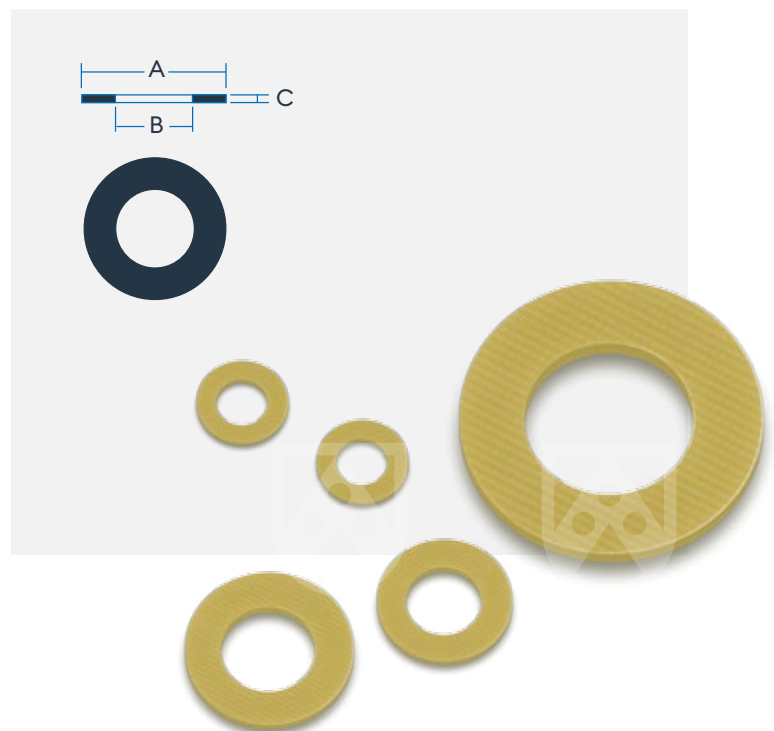

所给出的数值，是通过以统计为目的的检验和控制方法计算而得的平均值。

本文件的所有内容均基于本公司目前所掌握的专业知识与经验。尽管本公司提供相关数据，但用户/加工企业仍需自行检验、测试相关产品性能，因为使用本产品的过程可能会受多方影响。用户/加工企业以及相关产品/终端产品的分销公司，对终端产品是否适用于指定用途以及是否符合现行法律规定负全责。使用建议并不构成产品适用于建议用途的保证。

本文件的内容以及本公司就本文件做出的相关声明，均不构成任何质量保证。只有书面形式的明确声明才能构成有效的质量保证。我们保留根据技术进步改进产品的权利。本文所述之产品只能销售给具备相关专业知识的客户，而不能销售给终端消费者。如有询价请求或需要我们解释任何有关本产品使用的问题，敬请联系我们。如本产品将用于需要官方许可的应用，则用户/加工企业对于获得该审批许可负全责。

尽管我们提供相关使用建议，但用户/加工企业仍有责任明确是否会侵害到第三方的合法权利，并在必要时对此进行澄清。此外，我们建议您参考我们的《一般性商务条款》(AGB)。

请登录 [www.roechling.com/gtc](http://www.roechling.com/gtc)  
查阅该文件

The data stated above are average values verified on the basis of regular statistical tests and controls. All information in this publication is based on current technical knowledge and experience. Due to the large number of possible influences during processing and application, it does not exempt the user/processor from carrying out their own tests and trials. Responsibility for the evaluation of the end product for the intended use and compliance with the applicable relevant legal requirements lies exclusively with the user/processor as well as the distributor of the respective product/end product. Suggested uses do not constitute an assurance of suitability for the recommended purpose.

The information in this publication and our declarations in connection with this publication do not constitute acceptance of a guaranteed or warranted characteristic. Guarantee declarations require our separate express written declaration in order to be effective. We reserve the right to adapt the product to technical progress and new developments. The products described in this publication are only sold to customers with the appropriate expertise and not to consumers. Please do not hesitate to contact us if you have any questions or if you experience any specific application problems. If the application for which our products are used is subject to an official approval requirement, the user/processor is responsible for obtaining these approvals.

Our application recommendations do not exempt the user/processor from the obligation to examine and, if necessary, clarify the possibility of infringements of third-party rights. In all other respects, we refer to our General Terms and Conditions (GTC).

These are available at:  
[www.roechling.com/gtc](http://www.roechling.com/gtc)

## Europe

### GERMANY

#### **Röchling Engineering Plastics SE & Co. KG**

Röchlingstr. 1  
49733 Haren  
T +49 5934 701-0  
F +49 5934 701-299  
info@roechling-plastics.com  
www.roechling-industrial.com/de/haren

### FRANCE

#### **Röchling Permali Composites S.A.S.**

8, Rue André Fruchard  
54520 B.P.12, Maxéville  
T +33 383 342424  
F +33 383 322318  
info@roechling-permali.fr  
www.roechling-industrial.com/fr

#### **Röchling Permali Composites S.A.S.**

2, Rue de Barcelone  
69153 Decines Cedex  
T +33 472 148960  
F +33 472 371120  
roechling.decines@roechling-engineering.fr  
www.roechling-industrial.com/fr

## USA

#### **Röchling Glastic Composites**

4321 Glenridge Road  
44121 Cleveland (OH)  
T +1 216 486-0100  
F +1 216 486-1091  
info@glastic.com  
www.roechling-industrial.com/us

## Asia

### INDIA

#### **Röchling Engineering Plastics (India) Pvt. Ltd.**

701, , A' Wing, Leo Building  
24th Road, Khar West  
400 052 Mumbai  
T +91 224217 8787  
info@roechling-india.com  
www.roechling-industrial.com/india

### CHINA

#### **Roechling International (Shanghai) Co., Ltd.**

448, Chang Yang Street  
Suzhou Industrial Park  
215024 Suzhou  
T +86 512 6265 2899  
F +86 512 6265 2699  
rep@roechling.com.cn  
www.roechling-industrial.com/cn

劳士领国际贸易（上海）有限公司  
中国江苏省苏州工业园区长阳街448号  
邮编 215024 | (中华)  
电话: +86 512 6265 2899  
传真: +86 512 6265 2699  
rep@roechling.com.cn  
www.roechling-industrial.com/cn